

# VXE™ SmartLED®



## WARNING LIGHT



The **VXE SmartLED** offers the same sleek design and exceptional visibility as the original VXE Warning Light but with an embedded flasher, making it easier to install and use right out of the box.

### FEATURES

- Embedded flasher with 27 built-in flash patterns
- Scan-Lock™
- Steady-Lock™
- DUO™: 8 LEDs
- Directional light output
- Low profile/small design
- 1" diameter industry standard mounting grommet
- Clear or Smoked lens
- 9" pigtail included

### SPECS

Voltage: 10-30 VDC  
 Amps: 0.83 (peak), 0.52 (avg.)  
 Certifications: SAE Class 1, CA Title 13, IP67  
 Dimensions: 1.35" (3.43 cm) W x 1.40" (3.56 cm) H x 0.30" (8mm) D, 1" (25mm) Dia.  
 Operating Temperature: -40°F to 149°F (-40°C to 65°C)  
 Warranty: 10-year



VXF2J



VXF2F

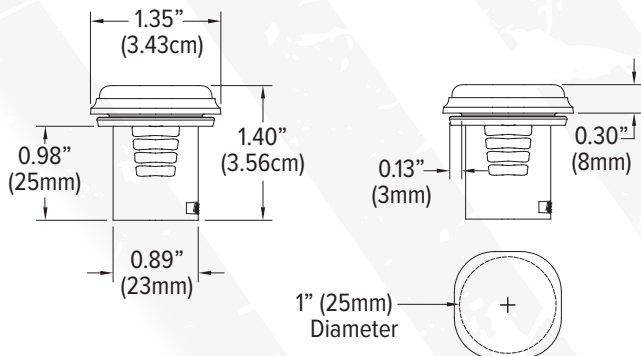

### MODELS

Model	Description
VXF2#	Directional DUO Lighthouse, Amber, Blue, Green, Red and/or White, 9" Pigtail
VXF2#X	Directional DUO Lighthouse, Amber, Blue, Green, Red and/or White with Smoked Lens, 9" Pigtail



Replace # symbol in model number with letter indicating DUO colors desired:  
 D = Red/White, E = Blue/White, F = Amber/White, H = Green/White, J = Red/Blue,  
 K = Red/Amber, L = Red/Green, M = Blue/Amber, N = Blue/Green, P = Amber/Green

**⚠ WARNING:** This product may contain chemicals known to the State of California to cause cancer and birth defects or other reproductive harm. For more information, visit [whelen.com/regulatory](http://whelen.com/regulatory).

All products proudly designed, manufactured, and assembled in the U.S.A.  
 • ISO 9001 Registered QMS

Whelen Engineering reserves the right to upgrade and improve products without notice.  
 © 2024 Whelen Engineering Company, Inc. Printed in U.S.A.  
 P13548A - 12/2024

**WHELEN**®  
 MANUFACTURED IN AMERICA

51 Winthrop Road  
 Chester, Connecticut 06412-0684  
 (860) 526-9504  
[www.whelen.com](http://www.whelen.com)

WHELEN ENGINEERING COMPANY, INC.